

50060

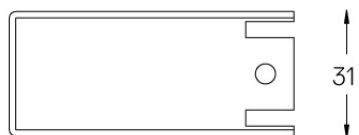
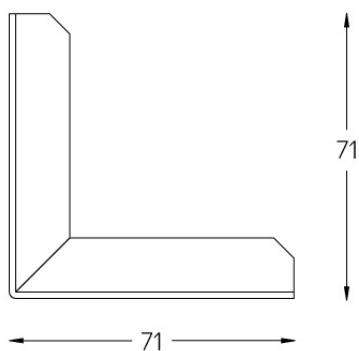

Conception : O/M

Plaque en acier de raccord de profilé pour angles à 90° entre mur et plafond. Peinture électrostatique 100 % polyester texturée.

Une entre deux sections de profilé.

Finishes

● .02 Noir / RAL 9005